

# AD20

## Penta-Band Internal PCB Antenna

### Features

- ◆ Compact Design
- ◆ Covers 850/900/1800/1900/2100 MHz bands
- ◆ Various cable/connector options
- ◆ Ideal for fixed and mobile terminals

### Specifications

Radiating element	Monopole Element
Frequency range	850/900/1800/1900/2100 MHz
Gain	0 dBi
Polarisation	Linear
Return loss	-10.0 dB
Power rating	10W
Cable / Connector	Various including MMCX, U.FL, SMA
Dimensions	47.2 x 15.1mm

### Popular Ordering Options

FADT35174-MR-10	AD20 with 100mm RG-178 and MMCX Connector
FADT35174-UF-10	AD20 with 100mm cable and U.FL Connector

Specifications subject to change without notice.

5 Little Balmer  
Buckingham Industrial Park  
Buckingham  
MK18 1TF  
UK

Tel: +44 (0)1280 824055  
Fax: +44 (0)1280 817179  
Email: sales@ead-ltd.com  
Web: www.ead-ltd.com

## AD20 | Penta-Band Internal PCB Antenna

### Return Loss

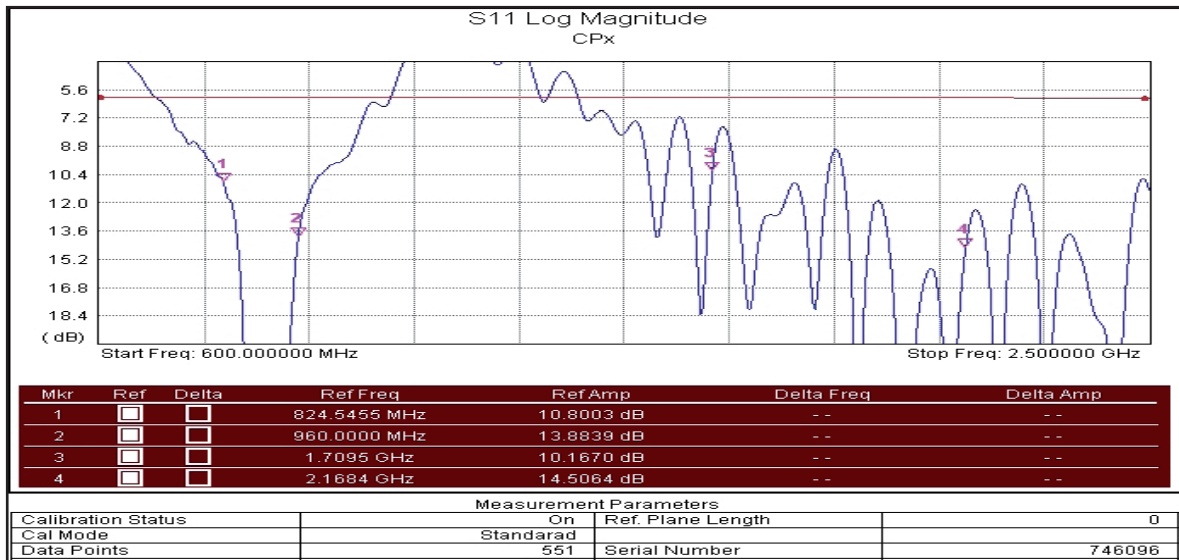

### Outline Drawing

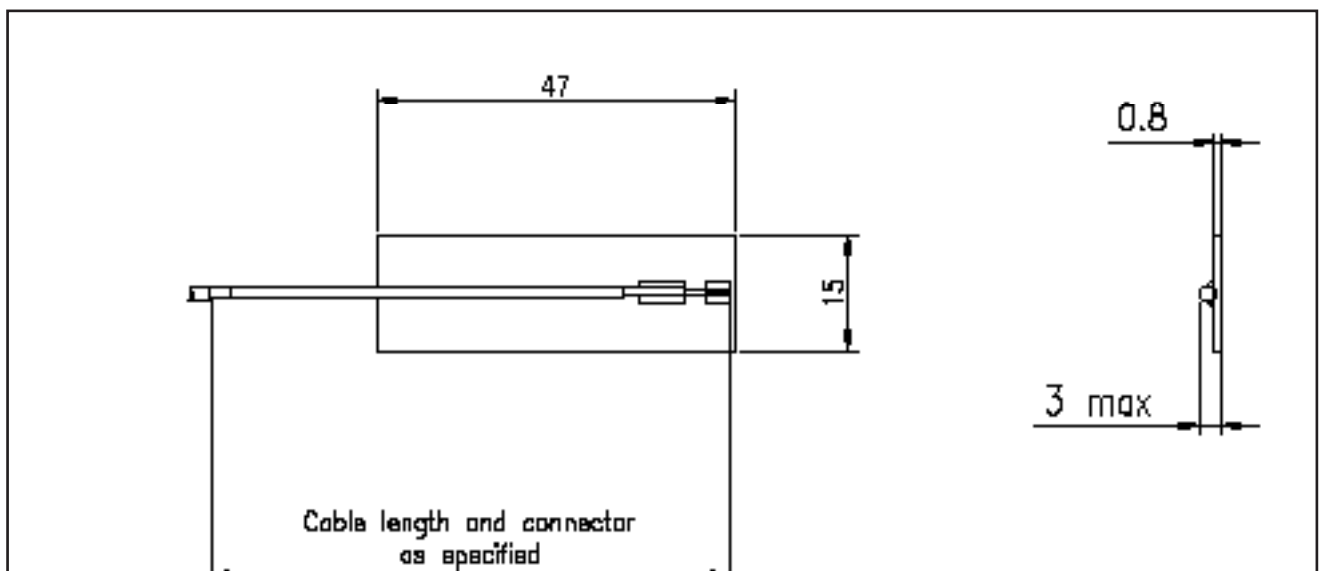

Specifications subject to change without notice.

5 Little Balmer  
Buckingham Industrial Park  
Buckingham  
MK18 1TF  
UK

Tel: +44 (0)1280 824055  
Fax: +44 (0)1280 817179  
Email: sales@ead-ltd.com  
Web: www.ead-ltd.com